

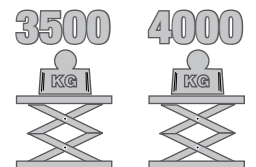

Automotive Equipment

362E - 412E

- ① Sollevatore a doppia forbice ad alto profilo ECO-Line
- ② High profilr double scissor lifts ECO-Line
- ③ Hochprofil-Doppelscherenbühnen ECO-Line



Ponti elevatori a double ciseaux ECO Line a incastrement

Elevadores de doble tijera ECO Line para empotrar

Elevadores de dupla tesoura ECO Line por encaixe

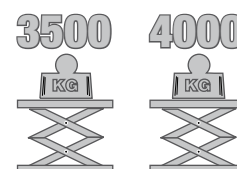
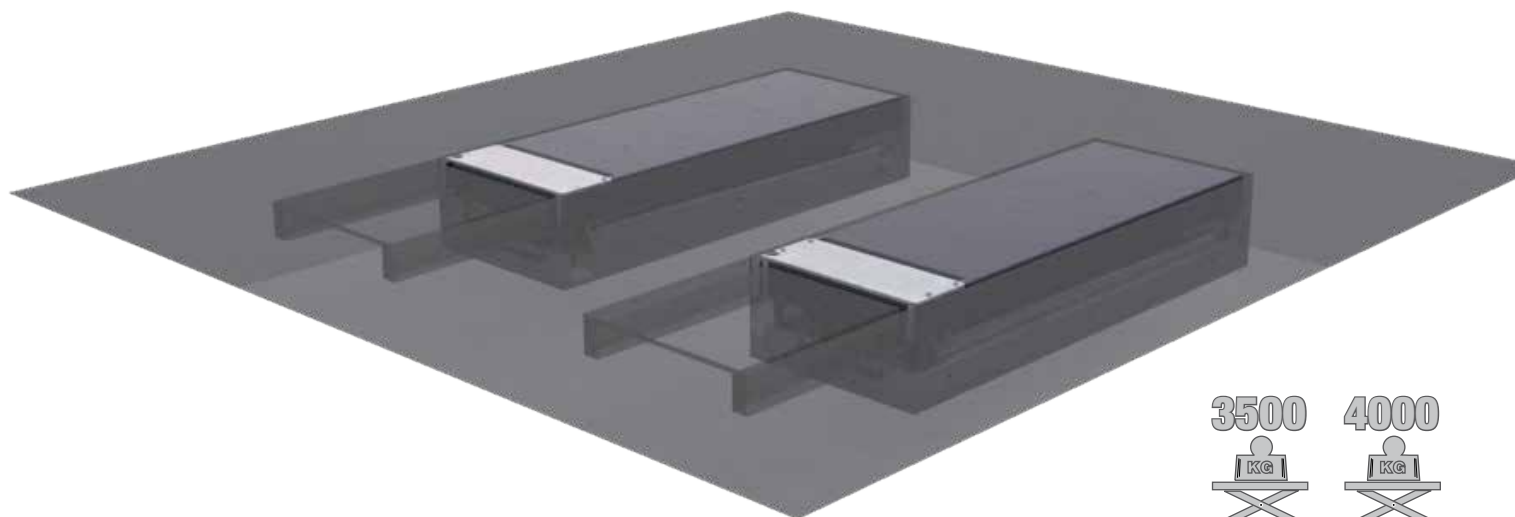

(IT)

CARATTERISTICHE PRINCIPALI

- Portata **3500 kg o 4000 kg**.
- Sempre **sistema doppio Master/Slave**, nessun blocco pneumatico
- **Nessuna elettronica sul lato a forbice** e nessun circuito stampato per ridurre le fonti di errore e mantenere il sistema il più semplice possibile
- Sistema di misura del volume nel serbatoio per CE/arresto di sicurezza
- **Boccole autolubrificanti** su tutte le parti rotanti
- Varietà di accessori disponibili

(EN)

MAIN FEATURES

- Capacity of **3.500 kg or 4.000 kg**.
- Always **double Master-Slave system**, no pneumatic lock
- **No electronics on scissor side** and no pcb in order to reduce sources of error and keep the system as simple as possible
- Volumen measurement system in the tank for CE / safety stop
- **Self-lubricating bushings** on all rotating parts
- Variety of accessories available

(DE)

HAUPTZEIGENSCHAFTEN

- Tragfähigkeit **3500 kg oder 4000 kg**.
- Stets mit **doppeltem Master/Slave System**, keine mechanische Verriegelung notwendig
- **Keine Elektronik auf der Scherenseite** und keine SPS-Steuerung, damit Fehlerquellen reduziert werden und das System so einfach wie möglich ist
- Messsystem des Volumens im Behälter für CE/Sicherheitsstopp
- **Selbstschmierende Buchsen** an allen rotierenden Teilen
- Große Zubehörauswahl

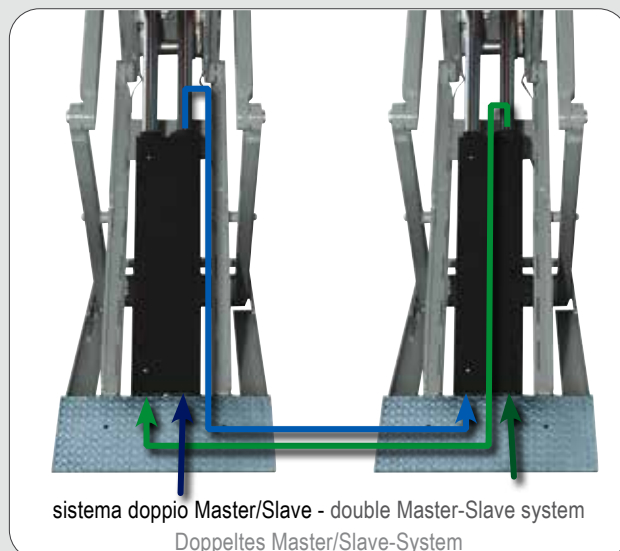



- ⒾT •Pedane e base con pattini di scorrimento di grande dimensione ed autolubrificanti.
- ⒾN •Runway and base with generously sized, selflubricating sliding shoes.
- ⒾE •Schienen und Unterstruktur mit selbstschmierenden Gleitböcken.



- ⒾT •4 registri fine corsa altezza minima delle pedane a terra, per una perfetta planarità.
- ⒾN •4 stroke limit adjuster screws for perfectly leveling of runways when lowered.
- ⒾE •4 Endschalter Mindesthöhe der Schienen am Boden für eine perfekte Ebenheit.



- ⒾT •Pedana con estensione a cassetto per una precisa regolazione della lunghezza.
- ⒾN •Runway with slide-out extension for precise length adjustment.
- ⒾE •Schienen mit Kastenverlängerung für eine genaue Längeneinstellung.

Sollevatore a doppia forbice ad alto profilo ECO-Line

High profilr double scissor lifts ECO-Line

Hochprofil-Doppelscherenbühnen ECO-Line

DATI TECNICI - TECHNICAL DATA - TECHNISCHE DATEN			Teco362E	Teco412E
CAPACITÀ MASSIMA	MAX. LOAD	MAX. TRAGFÄHIGKEIT	3500 kg	4000 kg
TEMPO DI SALITA	RAISING TIME	HUBFAHRTDAUER	40s	
TEMPO DI DISCESA	LOWERING TIME	SENKFAHRTDAUER	40s	
ALTEZZA MAX. DI SOLLEVAMENTO	MAX. LIFTING HEIGHT	MAX. HUBHÖHE	1940 mm	1900 mm
POTENZA MOTORE	MOTOR POWER	MOTORLEISTUNG	3kW	
ALIMENTAZIONE	POWER SUPPLY	STROMVERSORGUNG	230/400V - 3Ph - 50/60Hz 230V - 1Ph - 50Hz	
PESO IMBALLO	CRATE WEIGHT	VERPACKUNGSGEWICHT	700 kg	800 kg
DIMENSIONI IMBALLO	CRATE DIMENSIONS	VERPACKUNGSABMESSUNGEN	1000 x 1600 x 700 mm	

DIMENSIONI - DIMENSIONS - ABMESSUNGEN

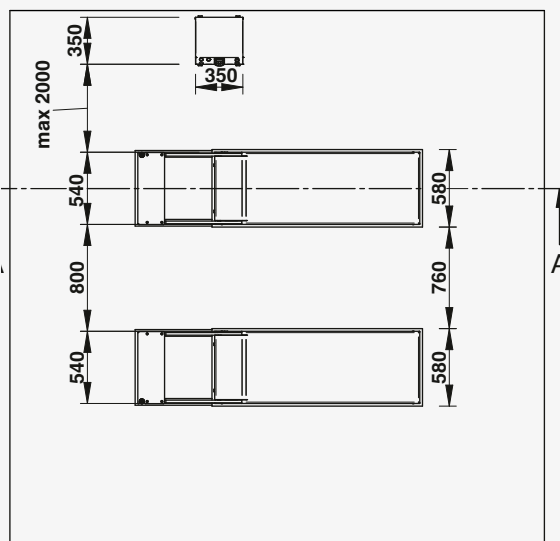
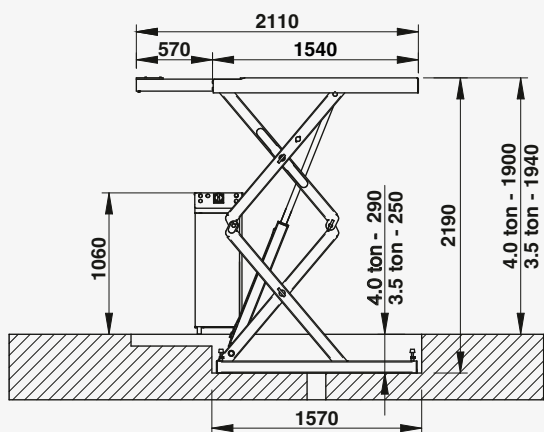

ACCESSORI A RICHIESTA - OPTIONAL ACCESSORIES - SONDERZUBEHÖR

A



B



C



OPZIONALI - OPTIONAL*

*Per altri accessori consultare l'apposito catalogo - For other optional accessories, refer to separate catalogue - Weitere Zubehöre Gemäß Verzeichni

•A_8-41100131 -Estensione tubi e cavi 1mt
-Extensions for pipes and cables 1mt
-Erweiterung, Rohren und Kabeln 1m

•B_8-41100132 -Estensione tubi e cavi 2mt
-Extensions for pipes and cables 2mt
-Erweiterung, Rohren und Kabeln 2m

•C_8-42300047 -Coppia di traverse con tamponi per fuoristrada
-Pair of beams with pads for all-terrain vehicles
-Paar Querträger und Auflagekissen für Geländewagen

Fotografie, caratteristiche ed i dati tecnici non sono vincolanti, possono subire modifiche senza preavviso - The manufacturer reserves the right to modify the features of its products at any time. - Die Fotografien, die angegebenen Eigenschaften und die technischen Daten sind nicht verbindlich und können ohne Vorankündigung geändert werden.

Cod. DPTC000442 Ed. 09_2023